

FF1-240 | FF1-800

FF1-240+2 x 4AL-FF1-240 | FF1-800+2 x 4AL-FF1-800







HANDLING

FF1-240+2 x 4AL-FF1-240





OPTIONALS

- **M-BASC** HANDELBAR INCLINATION ADJUSTABLE.
- **PVNIT** NITRILE VACUUM CUP OILED SURFACES.



ENH355	-		200 - 500 VAC (50 - 60 Hz) Thriphase/Monopahse
kW	480 W		83 L/min
	3 m		OK
	-		OK

FF1-240

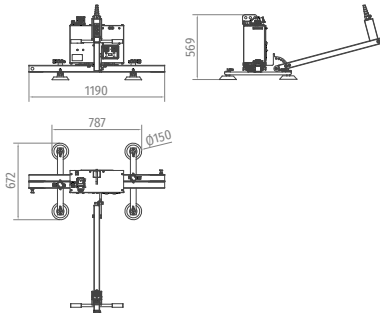
	120 kg
	60 kg



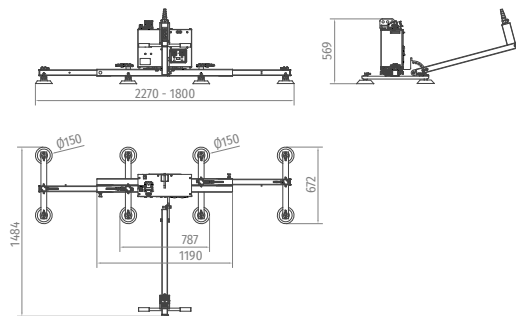

FF1-240+2 x 4AL-FF1-240

	240 kg
	80 kg



FF1-800

	400 kg
	65 kg

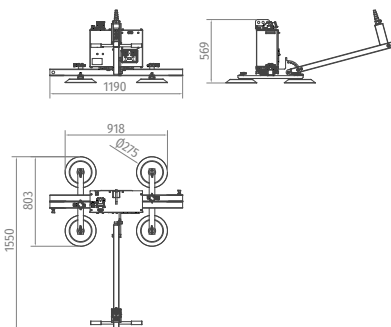

FF1-800+2 x 4AL-FF1-800

	800 kg
	85 kg

