



INDUSTRY 4.0

**TECNOCAT** WORK SERIES

**XL1-600G | XL1-600G+EXTENSIONS**

# XL1-600G | XL1-600G+EXTENSIONS

## WORK SERIES

### XL1-600G



 300 kg

 45 kg



CAMERA



REMOTE CONTROL



LIGHT





### XL1-600G+ EXTENSIONS



 600 kg

 65 kg

 OK
 0° - 360°
 0° - 60° - 90°
 36 L/min
 INDUSTRY 4.0

 60 W
 BATTERY CHARGE 220-240V AC 50-60 HZ
 OK - BATTERY 12V
 OK

## XL1-600G

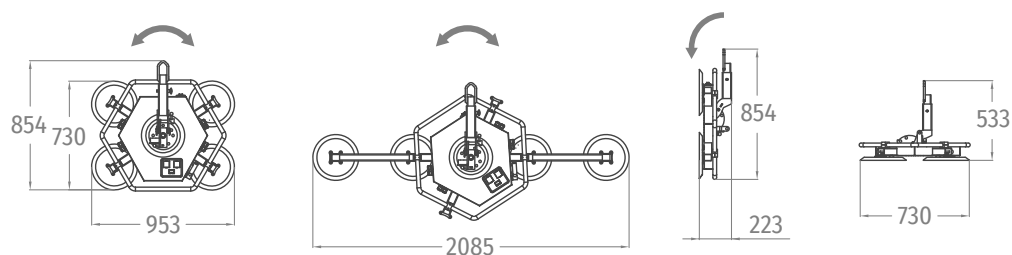

## XL1-600G+ EXTENSIONS

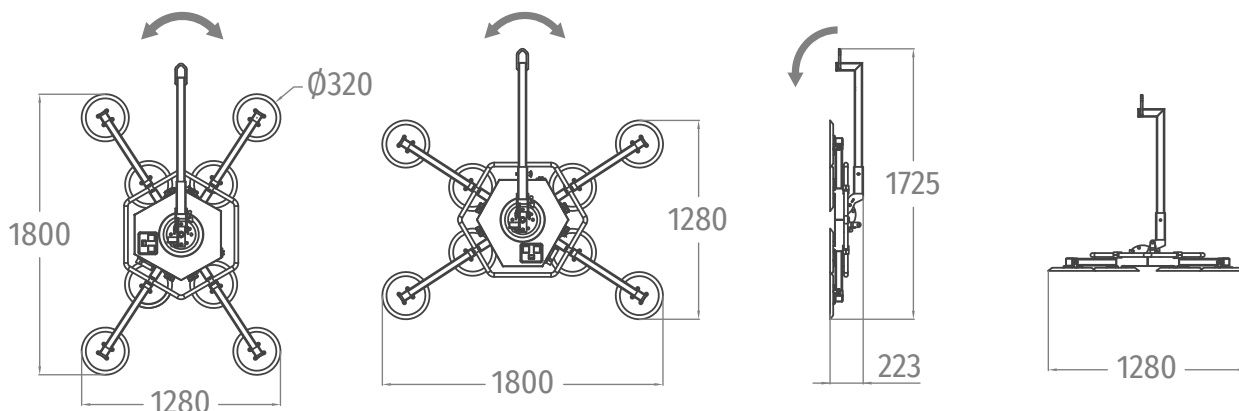

### INCLUDED

- SUPPORT WITH WHEELS
- FIXED HOLDING EXTENSION 2 SIZES

### OPTIONAL

- **CM-VL** METAL BOX
- HYDRAULIC PISTON
- REMOTE CONTROL
- CAMERA
- LIGHT
- A. CURVED ARM 9+9 CUPS Ø125 (270KG)
- B. CURVED ARM 5+5 CUPS Ø275 (500KG)

# PICTOGRAMS



ELECTRICAL POWER



MANUAL ROTATION EQUIPMENT



NOMINAL ELECTRIC POWER



PNEUMATIC ROTATION EQUIPMENT



ENERGY AUTONOMY BY BATTERIES



MOTORIZED ROTATION EQUIPMENT



PNEUMATIC SUPPLY



HYDRAULIC ROTATION EQUIPMENT



MAXIMUM LOAD CAPACITY



EQUIPMENT WEIGHT



MAXIMUM LOAD CAPACITY ACCORDING EN-13155



VACUUM SYSTEM AIR FLOW



TILTING EQUIPMENT



PUSHBUTTON CABLE LENGTH



MANUALLY TILTING EQUIPMENT



WIRELESS PUSHBUTTON



PNEUMATIC TILTING EQUIPMENT



LOAD CAPACITY ACCORDING EN-13155



MOTORIZED TILTING EQUIPMENT



EQUIPMENT SUPPORT SYSTEM



HYDRAULIC TILTING EQUIPMENT



LIFTING CRANE USABLE ROTATION



ROTATION EQUIPMENT



INDUSTRY 4.0