



**TECNOCAT** WORK SERIES



VR2-GB6 | VR2-GB6+8

# VR2-GB6 | VR2-GB6+8

## WORK SERIES

### VR2-GB6



	1440 kg
	720 kg
	154 kg

### VR2-GB6+8



	1460 kg
	1120 kg
	202 kg

WORK SERIES

ENH3ISS	OK
kW	950 W
	90° - 180° - 270° - 360°
	3 m

	200 - 500 VAC (50 - 60 Hz) + 24 VDC
	83 L/min
	0° - 90°
	—
	OK

## VR2-GB6

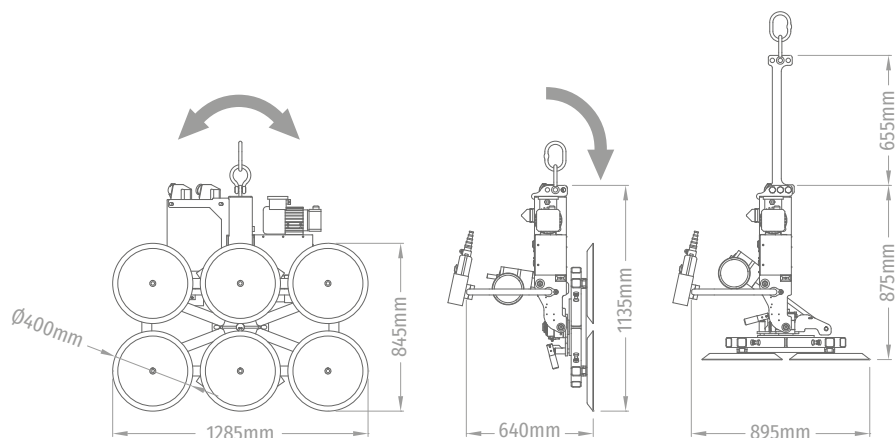

## VR2-GB6+8

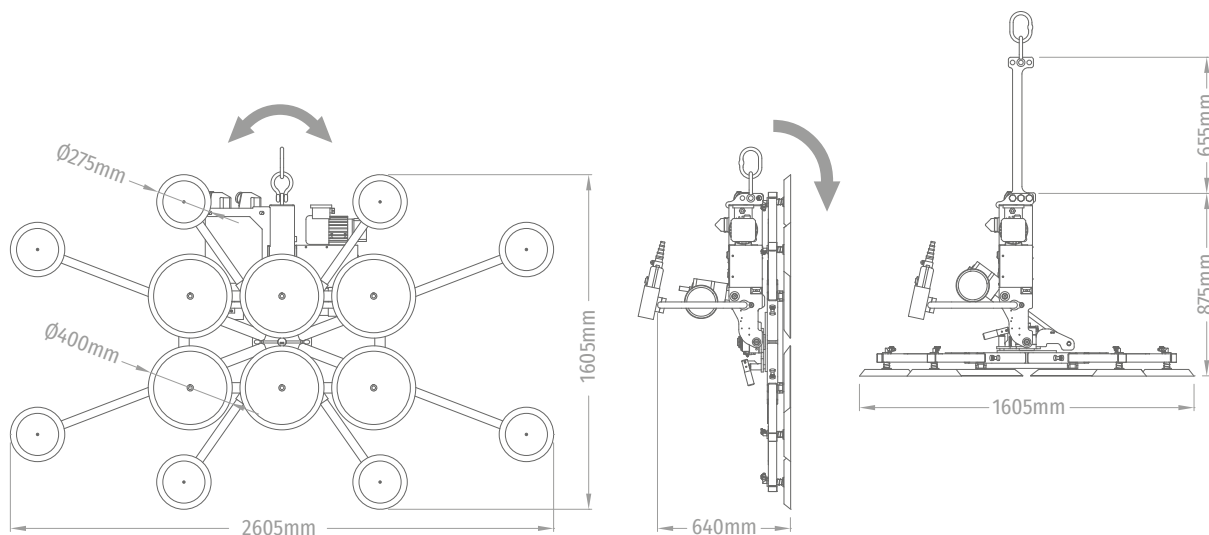

### INCLUDED

- MV-VOL WIRES AND PLUGS
- M-BOX METAL BOX
- ALF METAL HANGING EXTENSION

### OPTIONAL

- FU-P COVERS
- MI-100 WIRELESS PUSHBUTTON CONTROLLER
- AL-BOT PUSHBUTTON 10m. WIRE

# PICTOGRAMS



ELECTRICAL POWER



MANUAL ROTATION EQUIPMENT



NOMINAL ELECTRIC POWER



PNEUMATIC ROTATION EQUIPMENT



ENERGY AUTONOMY BY BATTERIES



MOTORIZED ROTATION EQUIPMENT



PNEUMATIC SUPPLY



HYDRAULIC ROTATION EQUIPMENT



MAXIMUM LOAD CAPACITY



EQUIPMENT WEIGHT



MAXIMUM LOAD CAPACITY ACCORDING EN-13155



VACUUM SYSTEM AIR FLOW



TILTING EQUIPMENT



PUSHBUTTON CABLE LENGTH



MANUALLY TILTING EQUIPMENT



WIRELESS PUSHBUTTON



PNEUMATIC TILTING EQUIPMENT



LOAD CAPACITY ACCORDING EN-13155



MOTORIZED TILTING EQUIPMENT



EQUIPMENT SUPPORT SYSTEM



HYDRAULIC TILTING EQUIPMENT



LIFTING CRANE USABLE ROTATION



ROTATION EQUIPMENT