

TECNOCAT **WORK SERIES**

VS1-GB4 | VS1-GB4+4

VS1-GB4 | VS1-GB4+4

WORK SERIES



VS1-GB4



	960 kg
	480 kg
	88 kg

VS1-GB4+4



	1360 kg
	680 kg
	112 kg

WORK SERIES

ENH3ISS	OK
kW	240 W
	90° - 180° - 270° - 360°
	3 m

	200 - 500 VAC (50 - 60 Hz) + 24 VDC
	83 L/min
	30° - 60° - 90°
	—
	OK

VS1-GB4

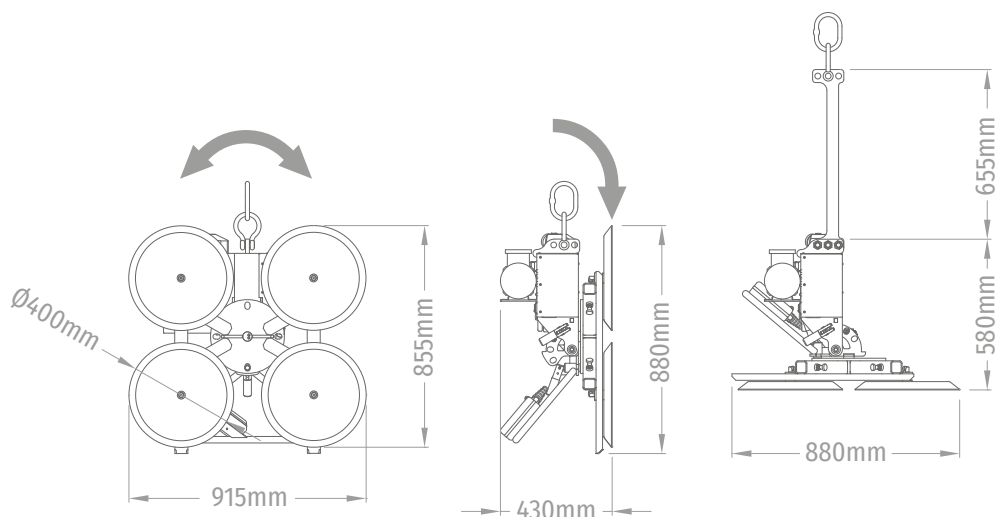

VS1-GB4+4

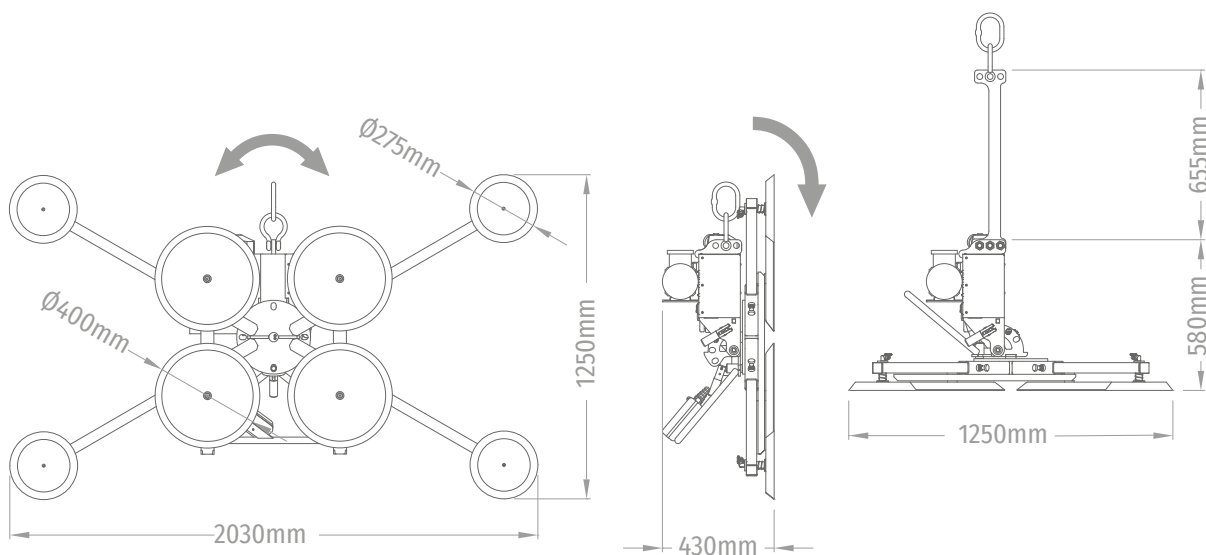

INCLUDED

- MV-VOL WIRES AND PLUGS
- M-BOX METAL BOX
- ALF METAL HANGING EXTENSION

OPTIONAL

- FU-P COVERS
- MI-100 WIRELESS PUSHBUTTON CONTROLLER
- AL-BOT PUSHBUTTON 10m. WIRE

PICTOGRAMS



ELECTRICAL POWER



MANUAL ROTATION EQUIPMENT



NOMINAL ELECTRIC POWER



PNEUMATIC ROTATION EQUIPMENT



ENERGY AUTONOMY BY BATTERIES



MOTORIZED ROTATION EQUIPMENT



PNEUMATIC SUPPLY



HYDRAULIC ROTATION EQUIPMENT



MAXIMUM LOAD CAPACITY



EQUIPMENT WEIGHT



MAXIMUM LOAD CAPACITY ACCORDING EN-13155



VACUUM SYSTEM AIR FLOW



TILTING EQUIPMENT



PUSHBUTTON CABLE LENGTH



MANUALLY TILTING EQUIPMENT



WIRELESS PUSHBUTTON



PNEUMATIC TILTING EQUIPMENT



LOAD CAPACITY ACCORDING EN-13155



MOTORIZED TILTING EQUIPMENT



EQUIPMENT SUPPORT SYSTEM



HYDRAULIC TILTING EQUIPMENT



LIFTING CRANE USABLE ROTATION



ROTATION EQUIPMENT