

TECNOCAT **WORK SERIES**

VS1-GB2 | VS1-GB2+2

VS1-GB2 | VS1-GB2+2

WORK SERIES

VS1-GB2



	480 kg
	240 kg
	68 kg

VS1-GB2+2



	680 kg
	340 kg
	80 kg

WORK SERIES

ENH3ISS	OK
kW	240 W
	90° - 180° - 270° - 360°
	3 m

	200 - 500 VAC (50 - 60 Hz) + 24 VDC
	83 L/min
	30° - 60° - 90°
	—
	OK

VS1-GB2

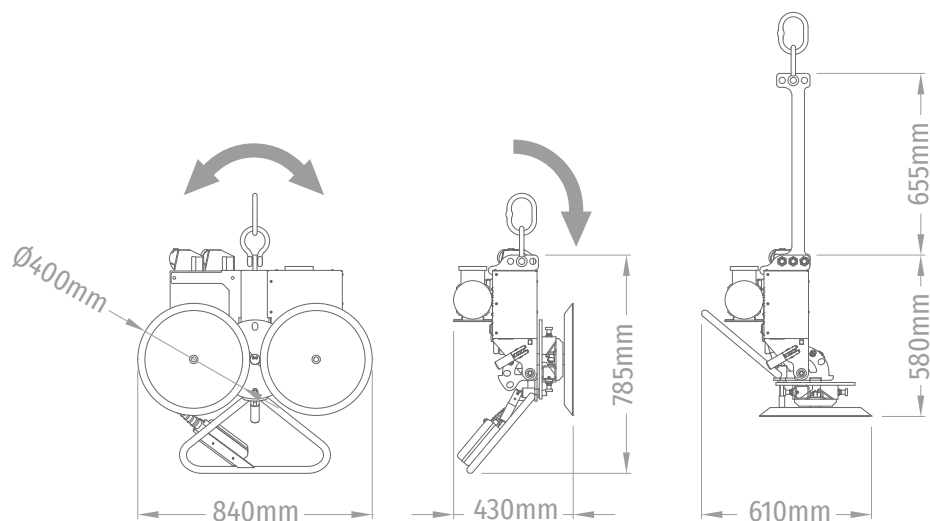

VS1-GB2+2

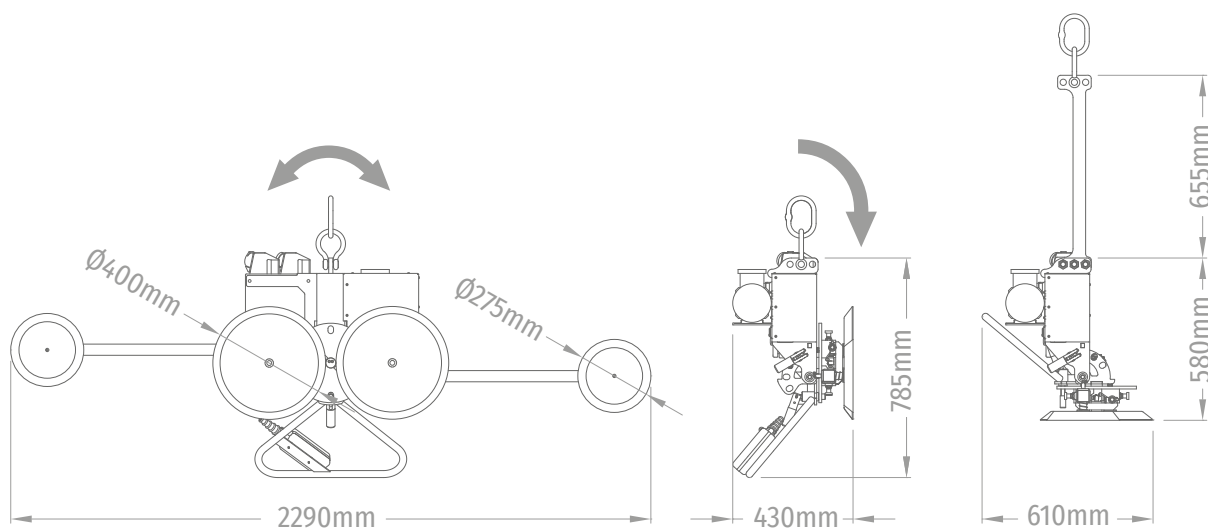

INCLUDED

- MV-VOL WIRES AND PLUGS
- M-BOX METAL BOX
- ALF METAL HANGING EXTENSION

OPTIONAL

- FU-P COVERS
- MI-100 WIRELESS PUSHBUTTON CONTROLLER
- AL-BOT PUSHBUTTON 10m. WIRE

PICTOGRAMS



ELECTRICAL POWER



NOMINAL ELECTRIC POWER



ENERGY AUTONOMY BY BATTERIES



PNEUMATIC SUPPLY



MAXIMUM LOAD CAPACITY



MAXIMUM LOAD CAPACITY ACCORDING EN-13155



TILTING EQUIPMENT



MANUALLY TILTING EQUIPMENT



PNEUMATIC TILTING EQUIPMENT



MOTORIZED TILTING EQUIPMENT



HYDRAULIC TILTING EQUIPMENT



ROTATION EQUIPMENT



MANUAL ROTATION EQUIPMENT



PNEUMATIC ROTATION EQUIPMENT



MOTORIZED ROTATION EQUIPMENT



HYDRAULIC ROTATION EQUIPMENT



EQUIPMENT WEIGHT



VACUUM SYSTEM AIR FLOW



PUSHBUTTON CABLE LENGTH



WIRELESS PUSHBUTTON



LOAD CAPACITY ACCORDING EN-13155



EQUIPMENT SUPPORT SYSTEM



LIFTING CRANE USABLE ROTATION