



**TECNOCAT** FACTORY SERIES

VR1-G4 | VR1-G4+4

# VR1-G4 | VR1-G4+4

FACTORY SERIES

## VR1-G4



	960 kg
	480 kg
	104 kg

FACTORY SERIES

## VR1-G4+4



	1360 kg
	680 kg
	128 kg

EN3155	OK
kW	850 W
⌚	0° - 360° - ENDLESS
🔌	—
📶	—

🔌	200 - 500 VAC (50 - 60 Hz)
🌀	83 L/min
🔧	—
🔋	—
🚲	OK

## VR1-G4

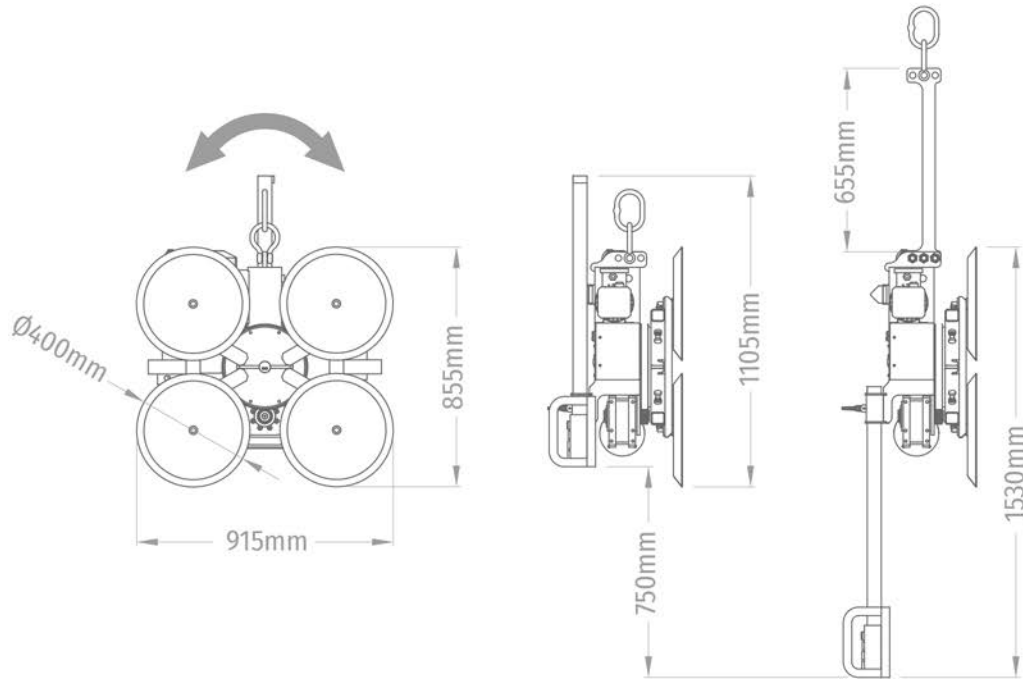

## VR1-G4+4

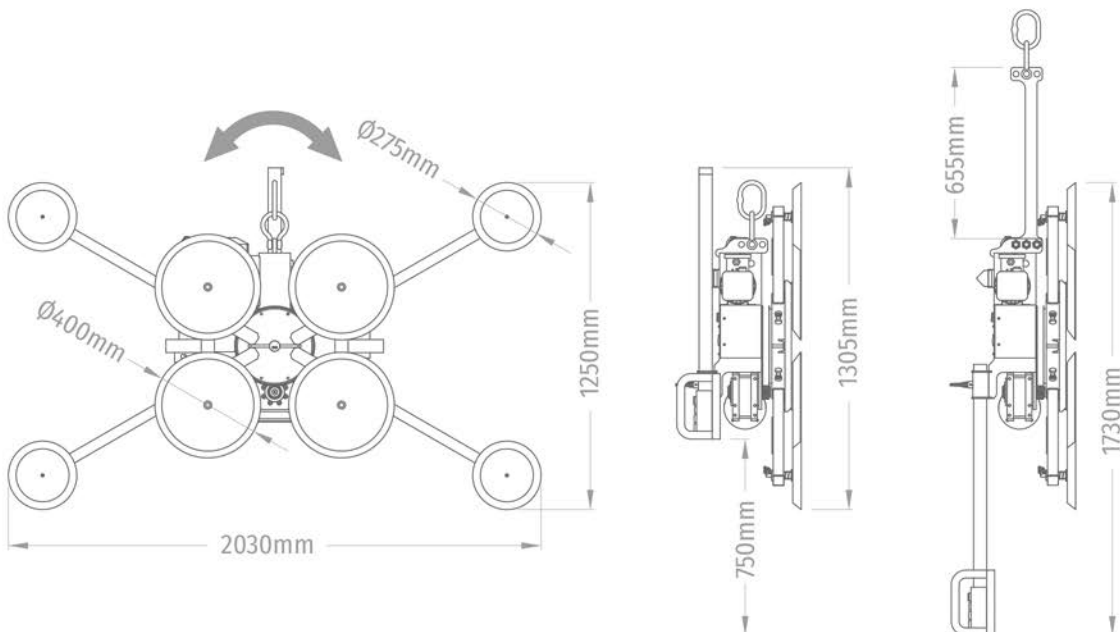

## INCLUDED

- M-BOX METAL BOX

# PICTOGRAMS



ELECTRICAL POWER



NOMINAL ELECTRIC POWER



ENERGY AUTONOMY BY BATTERIES



PNEUMATIC SUPPLY



MAXIMUM LOAD CAPACITY



MAXIMUM LOAD CAPACITY ACCORDING EN-13155



TILTING EQUIPMENT



MANUALLY TILTING EQUIPMENT



PNEUMATIC TILTING EQUIPMENT



MOTORIZED TILTING EQUIPMENT



HYDRAULIC TILTING EQUIPMENT



ROTATION EQUIPMENT



MANUAL ROTATION EQUIPMENT



PNEUMATIC ROTATION EQUIPMENT



MOTORIZED ROTATION EQUIPMENT



HYDRAULIC ROTATION EQUIPMENT



EQUIPMENT WEIGHT



VACUUM SYSTEM AIR FLOW



PUSHBUTTON CABLE LENGTH



WIRELESS PUSHBUTTON



LOAD CAPACITY ACCORDING EN-13155



EQUIPMENT SUPPORT SYSTEM



LIFTING CRANE USABLE ROTATION