

TECNOCAT HANDLING

VF3-F9 | VF3-F9+4

VF3-F9 | VF3-F9+4

HANDLING

VF3-F9+4

	1300 kg
	600 kg
	230 kg







VF3-F9+4 + PRO-MESH (OPTIONAL)



HANDLING

EN-3155	OK
kW	850 W
TC	—
	3 m
	OPTIONAL

	200 - 500 VAC (50 - 60 Hz) + 24 VDC
	80 L/min
	—
	—
	OK

VF3-F9

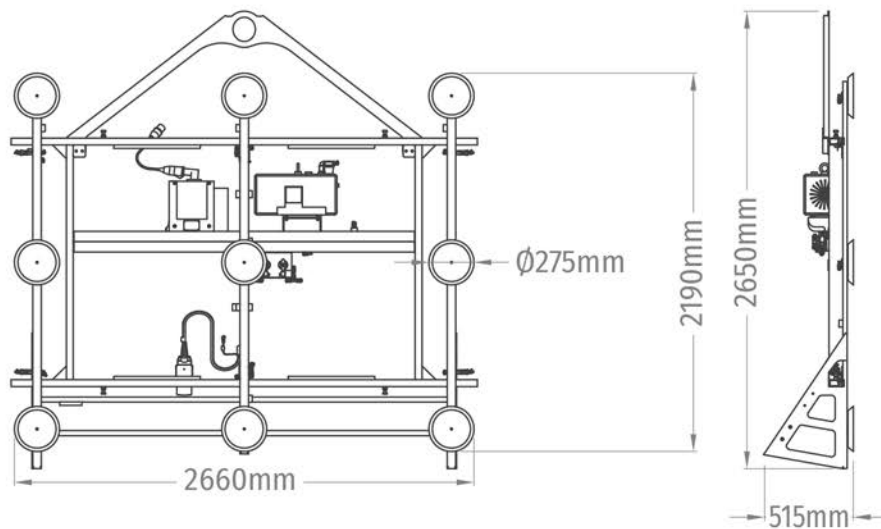

VF3-F9+4

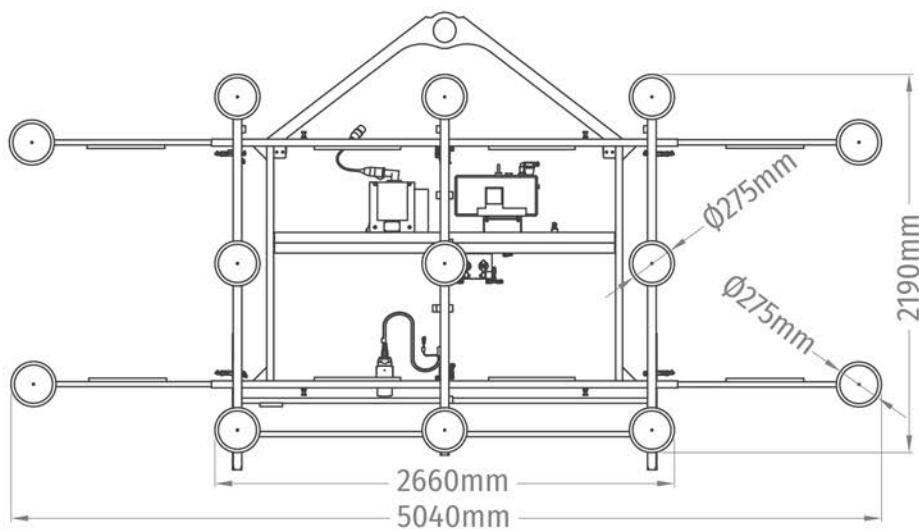

OPTIONAL

- PRO-MESH

PICTOGRAMS



ELECTRICAL POWER



NOMINAL ELECTRIC POWER



ENERGY AUTONOMY BY BATTERIES



PNEUMATIC SUPPLY



MAXIMUM LOAD CAPACITY



MAXIMUM LOAD CAPACITY ACCORDING EN-13155



TILTING EQUIPMENT



MANUALLY TILTING EQUIPMENT



PNEUMATIC TILTING EQUIPMENT



MOTORIZED TILTING EQUIPMENT



HYDRAULIC TILTING EQUIPMENT



ROTATION EQUIPMENT



MANUAL ROTATION EQUIPMENT



PNEUMATIC ROTATION EQUIPMENT



MOTORIZED ROTATION EQUIPMENT



HYDRAULIC ROTATION EQUIPMENT



EQUIPMENT WEIGHT



VACUUM SYSTEM AIR FLOW



PUSHBUTTON CABLE LENGTH



WIRELESS PUSHBUTTON



LOAD CAPACITY ACCORDING EN-13155



EQUIPMENT SUPPORT SYSTEM



LIFTING CRANE USABLE ROTATION