

TECNOCAT WORK SERIES

CGB24 | CGB36



CGB24 | CGB36 VACUUM FRAME FOR CURVED GLASS

WORK SERIES

CGB24 COMPATIBLE WITH: VS1 - VS2 - VR2 - VR3 - VR4



VR3-CGB24

	720 kg
	360 kg

M-BOX NOT INCLUDED

CGB36 COMPATIBLE WITH: VR3 - VR4



VR4-CGB36

	1080 kg
	540 kg

M-BOX NOT INCLUDED

WORK SERIES

EN-15155	OK
kW	—
TC	—
U	—
	—

	—
	—
	—
	—
	OK

CGB24 EXAMPLE

CGB36 EXAMPLE

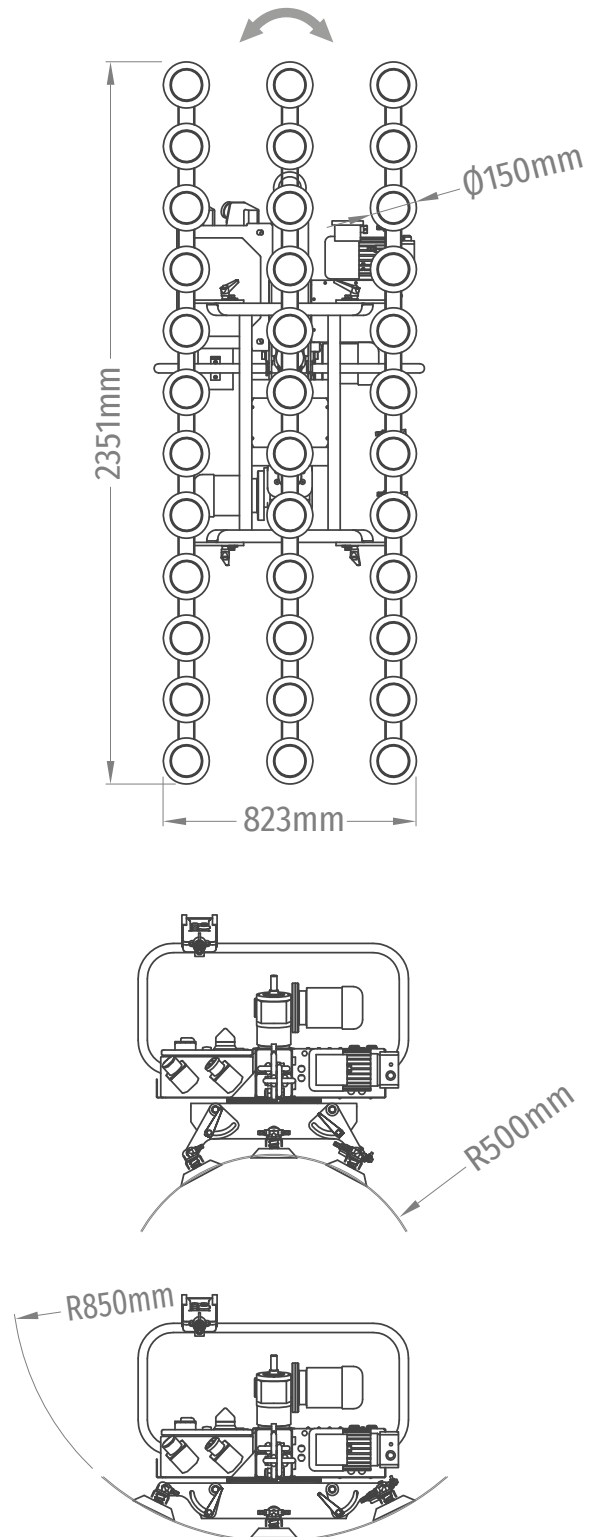
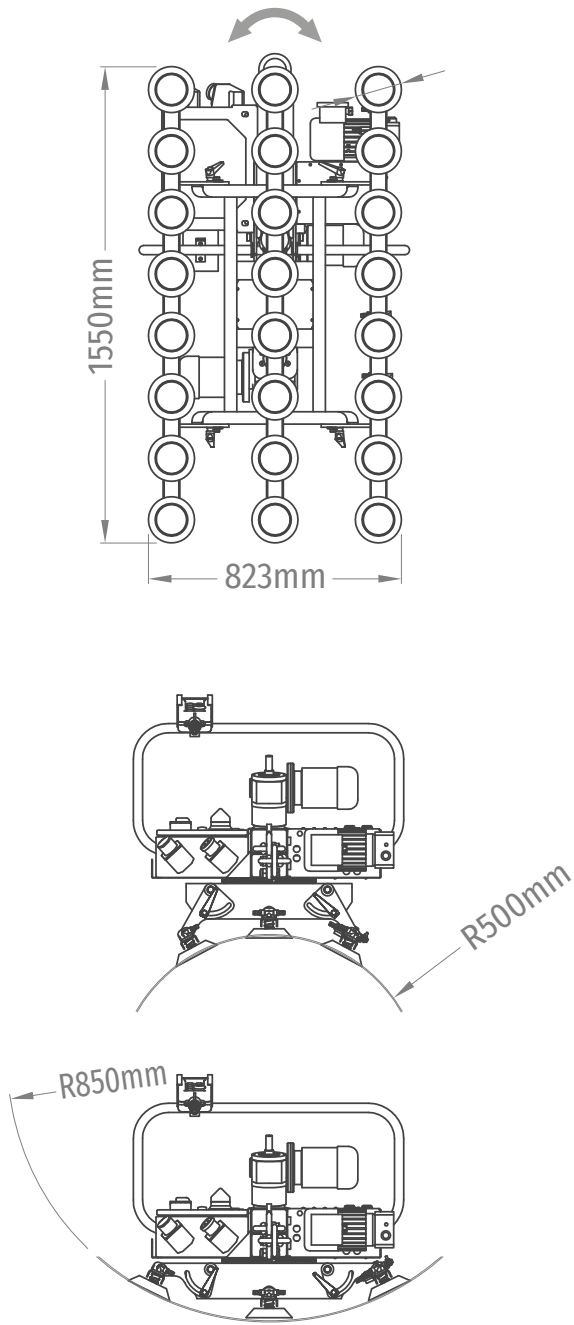

PICTOGRAMS



ELECTRICAL POWER



MANUAL ROTATION EQUIPMENT



NOMINAL ELECTRIC POWER



PNEUMATIC ROTATION EQUIPMENT



ENERGY AUTONOMY BY BATTERIES



MOTORIZED ROTATION EQUIPMENT



PNEUMATIC SUPPLY



HYDRAULIC ROTATION EQUIPMENT



MAXIMUM LOAD CAPACITY



EQUIPMENT WEIGHT



MAXIMUM LOAD CAPACITY ACCORDING EN-13155



VACUUM SYSTEM AIR FLOW



TILTING EQUIPMENT



PUSHBUTTON CABLE LENGTH



MANUALLY TILTING EQUIPMENT



WIRELESS PUSHBUTTON



PNEUMATIC TILTING EQUIPMENT



LOAD CAPACITY ACCORDING EN-13155



MOTORIZED TILTING EQUIPMENT



EQUIPMENT SUPPORT SYSTEM



HYDRAULIC TILTING EQUIPMENT



LIFTING CRANE USABLE ROTATION



ROTATION EQUIPMENT